

1. Details of Module and its structure

Module Detail	
Subject Name	Physics
Course Name	Physics 04 (Physics Part-2, Class XII)
Module Name/Title	Unit-07, Module-01: Photoelectric Effect Chapter-11: Dual nature of matter and radiation
Module Id	leph_201101_eContent
Pre-requisites	Atomic structure Electromagnetic waves Interference and diffraction of waves Effect of electric and magnetic fields on a moving charge Electric current Ionization of atoms, working of electroscope
Objectives	<p>After going through the module the students will be able to:</p> <ul style="list-style-type: none"> • Comprehend that electromagnetic radiations are associated with both wave and particle nature. • Describe Hertz's and Lenard's experiments and their main observations. • Understand the phenomenon of emission of electrons from a (photosensitive) surface when suitable em radiations fall on it. • Define the terms: work function, threshold frequency, stopping potential and photoelectric current
Keywords	Photoelectric effect, Hertz and Lenard experiment, emission of electrons, work function, threshold frequency, stopping potential , photoelectric current

2. Development Team

Role	Name	Affiliation
National MOOC Coordinator (NMC)	Prof Amarendra P. Behera	Central Institute of Educational Technology, NCERT, New Delhi
Programme Coordinator	Dr. Mohd Mamur Ali	Central Institute of Educational Technology, NCERT, New Delhi
Course Coordinator / PI	Anuradha Mathur	Central Institute of Educational Technology, NCERT, New Delhi
Subject Matter Expert (SME)	Anuradha Mathur	Central Institute of Educational Technology, NCERT, New Delhi
Review Team	Prof. V. B. Bhatia (Retd.) Associate Prof. N.K. Sehgal (Retd.) Prof. B. K. Sharma (Retd.)	Delhi University Delhi University DESM, NCERT, New Delhi

TABLE OF CONTENTS

1. Unit syllabus
2. Module wise distribution of unit syllabus
3. Words you must know
4. Introduction
5. Brief history and background
6. Electron emission
Photoelectric emission
7. Hertz observation
8. Hallwach and Lenard's observations
9. Dual nature of light
10. Summary

1. UNIT SYLLABUS

Unit 7

Dual Nature of Radiation and matter

Dual nature of radiation, photoelectric effect, Hertz and Lenard's observations, Einstein's photoelectric equation, particle nature of light

Matter waves, wave particle duality, nature of particles de Broglie relation, Davisson -Germer experiment (experimental details should be omitted only conclusion should be explained)

2. MODULE WISE DISTRIBUTION OF UNIT SYLLABUS

5 MODULES

<p>Module 1</p>	<ul style="list-style-type: none"> ● Introduction ● Electron emission ● Photo electric effect ● Hertz's observations ● Hallwach's and Lenard's observation ● Dual nature of light
<p>Module 2</p>	<ul style="list-style-type: none"> ● Photocell ● Experimental study of photoelectric effect ● photocurrent ● Effect of intensity of light on photo current ● Effect of positive and negative potential on photo current ● Stopping potential ● Effect of frequency of incident radiation on stopping potential ● Interpretations from the graphs drawn from above observations ● Photoelectric effect and wave theory of light

Module 3	<ul style="list-style-type: none"> • Einstein's photoelectric equation • Energy quantum of radiation -the photon • Relating Einstein's photoelectric equation and observations from experiments with photocell
Module 4	<ul style="list-style-type: none"> • Wave nature of matter • de- Broglie's hypothesis • de-Broglie wavelength • Planck's constant • Probability interpretation to matter waves • Davisson and Germer Experiment • Wave nature of electrons
Module 5	<ul style="list-style-type: none"> • Application of dual nature of radiation and matter • Electron microscope

MODULE 1

3. WORDS YOU MUST KNOW

Atomic structure: *atomic structure* is the positively charged nucleus and the negatively charged electrons circling around it, within an *atom*.

Electromagnetic waves: *Electromagnetic waves* are *waves* that are created as a result of vibrations between an electric field and a magnetic field. In other words, *EM waves* are composed of oscillating magnetic and electric fields

Interference and diffraction of waves: **interference** is a phenomenon in which two **waves** superimpose to form a resultant **wave** of greater or lower amplitude.

The **diffraction** phenomenon is described as the apparent bending of **waves** around small obstacles and the spreading out of **waves** past small openings.

Effect of electric and magnetic fields on a moving charge: A **charged** particle **moving** without acceleration **produces** an **electric** as well as a magnetic **field**. It **produces** an **electric field** because it's a **charge** particle. But when it is at rest, it doesn't **produce** a magnetic **field**. All of a sudden when it starts **moving**, it starts producing a magnetic **field**.

When a **charged** particle moves relative to a **magnetic field**, it will experience a force, unless it is traveling parallel to the **field**. The sign of the **charge**, the direction of the **magnetic field** and the direction the particle traveling will all affect the direction of the force experienced by the particle

Electric current: An *electric current* is a flow of *electric charge*.

Ionization of atoms: is the process by which an **atom** or a molecule acquires a negative or positive charge by gaining or losing electrons to form **ions**, often in conjunction with other chemical changes.

Ray and wave optics: *Ray optics*, describes light propagation in terms of *rays*. The *ray* in *geometric optics* is an idea useful for approximating the paths along which light propagates under certain circumstances. Light propagate in straight-line paths as they travel in a homogeneous medium.

Wave optics is the branch of **optics** that studies interference, diffraction, polarization, and other phenomena for which the **ray** approximation of geometric **optics** is not valid.

Plotting and interpreting graphs: graphs in scientific world are between any two physical quantities and show the dependence of one on the other.

Analysis and deductions from the graphs show variations and interpretations can give meaning to the study, example: u-v graphs of experimental observations from optics experiments, not only show the variation and dependence of one physical quantity on another under the constraints of the study.

Graphs can be linked with a mathematical equation: all graphs have a mathematical relation. hence there will always be an equation related to the segment of the graph drawn, the graph could be a straight line, a curve, a parabola, a hyperbola

4. INTRODUCTION

The discovery of the phenomenon of **photoelectric effect** has been one of the most important discoveries in modern science.

The experimental observations associated with this phenomenon made us realize that our, ‘till then’, widely accepted picture of the nature of light – The electromagnetic (wave) theory of light – was quite inadequate to understand this phenomenon.

A ‘**new picture**’ of light was needed and it was provided by **Einstein** through his ‘**photon theory**’ of light. This theory, regarded light as a stream of particles. Attempts to understand photoelectric effect thus led us to realize that light, which was being regarded as ‘waves’, could also behave like ‘particles’. This led to the idea of ‘wave-particle duality’ vis-à-vis the nature of light.

Attempts to understand this ‘**duality**’, and related phenomenon, led to far reaching, and very important developments, in the basic theories of Physics.

It is interesting to note that the ‘wave-particle duality’, initially associated with radiation, was later-on, extended to particles, or matter, also.

We will start the module with a brief history.

5. BRIEF HISTORY AND BACKGROUND

The **Maxwell's equations** of electromagnetism and Hertz experiments on the generation and detection of electromagnetic waves in 1887 strongly established the wave nature of light. Towards the same period at the end of 19th century, experimental investigations on conduction of electricity (electric discharge) through gases at low pressure in a discharge tube led to many historic discoveries.

The discovery of X-rays by **Roentgen** in 1895, and of electron by **J. J. Thomson** in 1897, were important milestones in the understanding of atomic structure. It was found that at sufficiently low pressure of about 0.001 mm of mercury column, a discharge took place between the two electrodes on applying the electric field to the gas in the discharge tube. A fluorescent glow appeared on the glass opposite to cathode. The colour of glow of the glass depended on the type of glass, it being yellowish-green for soda glass. The cause of this fluorescence was attributed to the radiation which appeared to be coming from the cathode. These cathode rays were discovered, in 1870, by **William Crookes** who later, in 1879, suggested that these rays consisted of streams of fast moving negatively charged particles.

The British physicist **J. J. Thomson** (1856-1940) confirmed this hypothesis. By applying mutually perpendicular electric and magnetic fields across the discharge tube, J. J. Thomson was the first to determine experimentally the speed and the specific charge [charge to mass ratio (e/m)] of the cathode ray particles.

They were found to travel with speeds ranging from about 0.1 to 0.2 times the speed of light (3×10^8 m/s). The presently accepted value of e/m is 1.76×10^{11} C/kg. Further, the value of e/m was found to be independent of the nature of the material/metal used as the cathode (emitter), or the gas introduced in the discharge tube.

This observation suggested the universality of the cathode ray particles. **Around the same time, in 1887, it was found that certain metals, when irradiated by ultraviolet light, emitted negatively charged particles having small speeds.**

Also, certain metals when heated to a high temperature were found to emit negatively charged particles. The value of e/m of these particles was found to be the same as that for cathode ray particles. These observations thus established that all these particles, although produced under different conditions, were identical in nature. J. J. Thomson, in 1897, named these particles as electrons, and suggested that they were fundamental, universal constituents of matter.

For his epoch-making discovery of electron, through his theoretical and experimental investigations on conduction of electricity by gasses, he was awarded the Nobel Prize in Physics in 1906. In 1913, the American physicist **R. A. Millikan** (1868-1953) performed the pioneering oil-drop experiment for the precise measurement of the charge on an electron. He found that the charge on an oil-droplet was always an integral multiple of an elementary

charge, 1.602×10^{-19} C. Millikan's experiment established that electric charge is quantised. From the values of charge (e) and specific charge (e/m), the mass (m) of the electron could be determined.

The concept of 'wave nature of matter' was postulated by **de Broglie in 1924**. It was confirmed experimentally by **Davisson and Germer** a few years after its postulation. Therefore, the realization was that 'wave nature' and 'particle nature' can be viewed as the 'two sides of a coin'. **Both matter and radiation can exhibit either of these 'natures', depending on the experimental situation.**

The phenomenon of photoelectric effect and the concept of 'matter waves', have been put to very useful and interesting practical applications. We are aware of **photocells, automatic doors at shops and malls, automatic light switches that turn on the lights as soon as the intensity drops.**

We have also heard of **electron microscope** that has the ability to give very high resolutions. In this unit we shall discuss photoelectric effect and understand how it can be used in daily life. We shall also discuss matter waves and the concept of wave particle duality.

The idea of duality originated in a debate over the nature of light and matter that dates back to the 17th century.

Some scientists associated with the study were **Huygens, Newton, Bohr, Einstein, de Broglie and others.**

You can study more about their work from the internet.

A short brief about them is given here.

Christian Huygens (1629–1695) He is known for his famous wave theory of light.

Sir Isaac Newton (1642–1727) He is known for Newtonian Mechanics, Universal Gravitation and Optics. Read more http://en.wikipedia.org/wiki/Isaac_Newton

Albert Einstein (1879–1955) He is known for general relativity and special relativity theories, Photoelectric effect, Mass-energy equivalence **and Bose–Einstein statistics**. Nobel Prize in Physics (1921)

Louis de Broglie (1892–1987) He is known for wave nature of electrons and the idea of de Broglie wavelength. Noble prize in Physics (1929)

Niels Bohr (1885–1962) He is known for Bohr model of the hydrogen atom,

Somerfield–Bohr theory and Bohr magnetron. Nobel Prize in Physics (1922)

Important Milestones

It is important for each one of us to respect and learn about the work done over the centuries. It also tells us that the current explanations may change with better

understanding and further experimentation. The Higgs Boson experiment at CERN, is likely to modify the understanding of the microscopic world of atoms and nuclei.

100AD Early Greeks measured the angle of refraction in water

900AD -1020 Ibn al- Haitham studied the glass lenses and their properties

1608 Galilio Galilie learnt how to grind and polish lenses, combining them to make telescopes.

1637 Using corpuscular model Descartes derived Snell's law

1665 Francisco Grimaldi was probably the first to observe diffraction of light

1666 Newton studied refraction as a function of colour

1672 Newton said in a published paper that white light is made up of seven colours

1676 Olaf Roemer determined the speed of light

1678 Christaan Huygens put forward the wave theory of light

1704 Newton proposed the corpuscular theory of light

1801 Thomas Young performed the double slit interference experiment

1819 Fraunhofer demonstrated diffraction patterns

1864 Maxwell predicted the presence of electromagnetic waves and said that light is also an electromagnetic wave

1881 AA Michelson built an interferometer to make precise measurements with light, including speed of light

1887 Heinrich Hertz discovered the photoelectric effect in which a metal surface, irradiated by a suitable beam of light, would emit electrons

1900 In order to derive the blackbody radiation formula, Planck made the unconventional assumption that the oscillations can only exchange energies in discrete amounts.

1905 In a paper entitled on a heuristic point of view about the creation and conversion of light. Einstein introduced the 'light quanta'. In this paper he wrote that for explanation of phenomenon, like blackbody radiation and emission of electrons by ultraviolet light, it is necessary to assume that when a ray of light, starting from a point, is propagated, the energy is not continuously distributed over an ever increasing volume, but consists of a finite number of energy quanta, localised in space, which move without being divided and which can be absorbed or emitted only as a whole. Einstein received the Nobel prize in physics for his discovery of the law of photoelectric effect.

6. ELECTRON EMISSION

We know that metals have free electrons which contribute towards conduction of electricity and heat.

The electrons cannot normally escape from the metal surface. Why? When an electron escapes from the metal surface, it is quite likely to be quickly absorbed back as the metal becomes positive. One can thus understand that it is captive within the metal even though it can freely move within the metal.

A certain minimum (external) energy is required to be given to an electron for it to escape a given metal surface.

This is known as the **work function for that metal**.

It is denoted by ϕ_0 and is measured in electron volt eV.

One eV is the energy gained by an electron when it is accelerated by a potential difference of 1 Volt.

$$1 \text{ eV} = 1.602 \times 10^{-19} \text{ J.}$$

Work Function of Some Metals

Metal	Work function ϕ_0 (eV)	Metal	Work function ϕ_0 (eV)
Cs	2.14	Al	4.28
K	2.30	Hg	4.49
Na	2.75	Cu	4.65
Ca	3.20	Ag	4.70
Mo	4.17	Ni	5.15
Pb	4.25	Pt	5.65

In the above table, metals have been placed in order of increasing atomic mass.

THINK ABOUT THESE

- The size of the atom effects the value of work function?
- From which metal, electron emission would be easier? And why?
- Do you think that work function ϕ_0 would depend upon the material of the metal, temperature and the nature of its surface, impurities on its surface?
- Work function of platinum is the highest ($\phi_0 = 5.65\text{eV}$) and is least for Caesium ($\phi_0 = 2.1\text{eV}$). If energy, equal to the work function is required by electrons to escape, which of the two will need lesser energy?

One often says that conductors / metals, conduct electricity because they have free electrons,

This however, does not mean that the **electrons can move out of the metal surface by themselves**. But when we talk about electron escaping the metal surface, it actually makes the surface positive as it would now be deficient in electrons. **Thus, one realizes that we need to supply (external) energy, to the (free) electrons in a metal, to enable them to escape from the metal. This supply of (external) energy can be done in many ways.**

DIFFERENT WAYS OF ELECTRON EMISSION.

a) Thermionic emission:

In thermionic (thermos=heat) emission, the metal is heated. Due to this, the kinetic energy of electrons is increased and if the kinetic energy is sufficient enough to overcome the binding energy, then the electrons can get free from the forces of attraction due to the ions and hence are emitted by the metal surface.

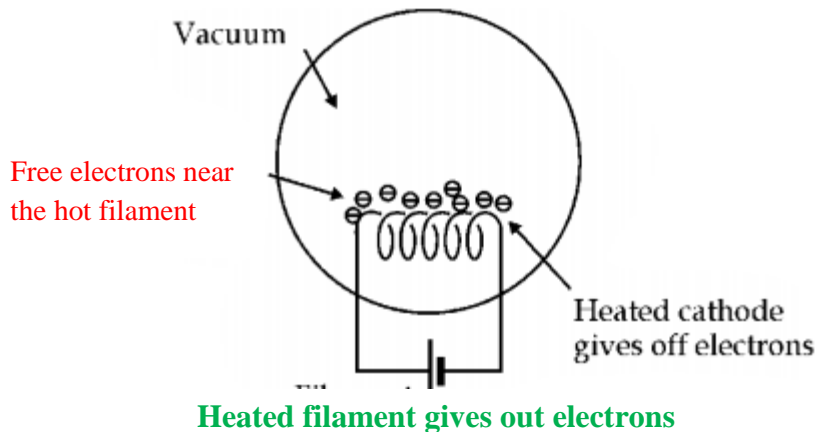

If a suitable electric field is applied appropriately the current will flow in the circuit.

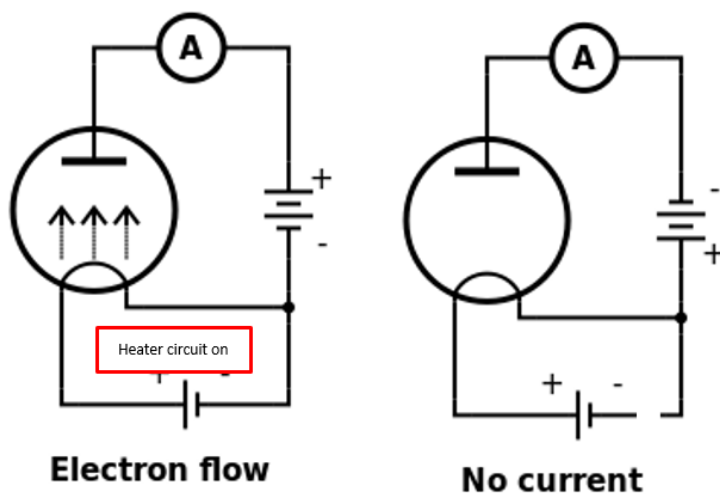

<https://upload.wikimedia.org/wikipedia/commons/thumb/c/ce/EdisonEffect.svg/194px-EdisonEffect.svg.png>

b) Field emission:

It is done by applying a very strong electric field, of the order of 10^8Vm^{-1} . In field emission, a large electric field is applied across the metal. The electrons then experience the forces due to the electric field and hence can get emitted from the metal surface.

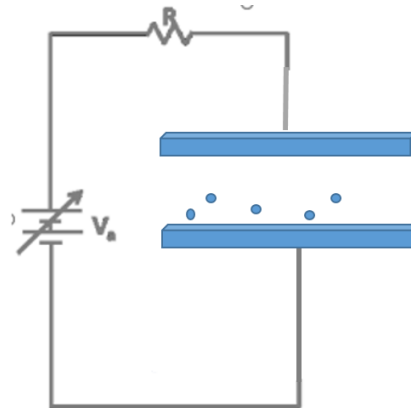
**c) Photo electric emission:**

When light of a suitable frequency falls on a metal surface, electrons are emitted from it. The electrons so emitted are called photoelectrons.

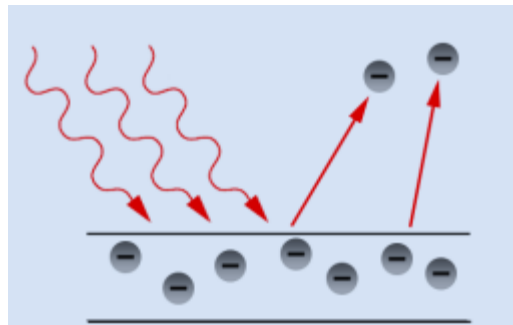

The apparatus to study the photoelectric effect is a 'set up' of two plates inside a vacuum tube. The battery is arranged so that its negative is connected to one of the plates, while the other is connected to positive terminal. For advanced work, a spectrometer may be used to give the exact wavelength/ frequency of incident light on the cathode. It is also possible to replace the cathode material, and carry out material related effects for the same frequency of incident radiations.

d)Secondary emission:

electrons are emitted from the surface by striking it with high energy electrons.

These are the electrons emitted from the TV screen surface when in use. The electron beams showing the pictures cause the emission of electrons. You can check the charge around the TV screen by going near it and waving a paper napkin in front of it.

We have understood from previous considerations that the minimum energy required for the electron emission from the metal surface can be supplied to the free electrons by number of different methods.

Let us understand how light (electromagnetic radiation in the visible range and close to it – ultra violet rays) falling on a metal emits electrons.

7. HERTZ OBSERVATION

The phenomenon of photoelectric effect was discovered by Heinrich Hertz in 1887.

Hertz was experimenting on production of electromagnetic waves by means of a spark discharge. He had evacuated a glass tube and placed two electrodes in it. He connected these to a high voltage source. A spark appeared between the electrodes.

During the course of his investigations, he observed that the spark was enhanced when the emitter plate was illuminated by **ultraviolet light**.

It was this **chance observation** that led to the discovery of the photoelectric effect. When light falls on a metal surface, some electrons near the surface, absorb enough energy from the incident radiations to overcome the attraction of positive ions in the material of the surface.

After gaining the required energy from the incident light, the electrons escape from the surface of the metal. Hertz credited the ultraviolet light to enhance the spark as it gave energy to the emitter plate.

8. HALLWACHS' AND LENARDS' OBSERVATIONS

The two scientists William Hallwachs and Philipp Lenard studied photoelectric effect in detail during 1886-1902.

Toward the end of the nineteenth century, a number of experiments were performed related to the emission of electrons from a metal surface when light (particularly ultraviolet light) falls on it

Lenard observed that when ultraviolet radiations were allowed to fall on the emitter plate of an evacuated glass tube, enclosing two electrodes (metal plates), current started flowing in the circuit connecting the plates. As soon as the ultraviolet radiations were stopped, the current flow also stopped. These observations proved that it was ultraviolet radiations, falling on the emitter plate, that ejected some charged particles from the emitter and the positive plate attracted them.

Since they were attracted by the positive plate, the charged particles must be carrying a negative charge.

Later, further studies showed that these were electrons.

Hallwachs carried these studies further by taking a zinc plate and an electroscope. The zinc plate was connected to the electroscope (uncharged, negatively charged and positively charged in turn). He observed that:

- As soon as zinc plate was irradiated by ultraviolet light, the zinc plate became positively charged.
- When a positively charged zinc plate is illuminated by ultraviolet light it became more positive.
- When a negatively charged zinc plate was irradiated by ultraviolet light it lost its charge.

Studies, that followed, showed that different metals emit electrons when irradiated by different electromagnetic radiations. For example, alkali metals (sodium, caesium, potassium) emit electrons with X-rays ultraviolet light as also with visible light, except red and orange light.

Heavy metals, like zinc, cadmium, magnesium, emit electrons only when ultraviolet radiations fall on them.

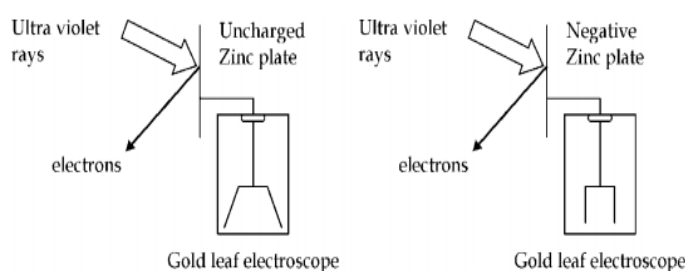

EXAMPLE

Alkali metals like Li, Na, K and Cs show photo electric effect with visible light but metals like Zn, Cd and Mg respond to ultraviolet light. Why?

SOLUTION

Frequency of visible light is more than that for ultraviolet light

EXAMPLE

Why do we not observe the phenomenon of photoelectric effect with non-metals?

Solution

For non-metals work function is very high

9. DUAL NATURE OF LIGHT

After the discovery of photoelectric effect as a result of experiments the behaviour of light as wave as established by wave optics (experiments by Thomas Young- double slit experiment diffraction fringes pattern, polarisation) and particle nature as in photoelectric effect caused a lot of dilemma in the scientific world.

10. SUMMARY

We have learnt the following from this module

The early scientific research that lead to understanding dual nature of light.

Electrons can be ejected from solid martial by giving them sufficient energy to overcome the forces that keep the electrons inside the atom. In this connection we learnt

- **Work function:** the minimum amount of energy required by an electron to just escape from the metal surface is known as work function of the metal. This is generally measured in electron volts (eV).
- **Electron volt:** it is the energy gained by an electron when it is accelerated through a potential difference of 1 volt $1 \text{ eV} = 1.6 \times 10^{-19} \text{ joules}$
- **Electron emission:** the phenomenon of emission of electrons from a metal surface. This occurs in the following ways
 - **Thermionic emission:** electrons are emitted from the surface when the surface is heated
 - **Field emission:** electrons are emitted from a surface when subjected to very high electric field
 - **Photo electric emission:** electrons are emitted from a metal surface when electromagnetic radiations of suitable frequency is incident on the surface.
 - **Secondary emission:** electrons are emitted from the surface by striking it with high energy electrons.
- **Early experiments** confirming photo electric effect were performed by Hallwach and Lenard
- It was found that certain metals like zinc, cadmium, magnesium, etc., responded only to ultraviolet light, having short wavelength, to cause electron emission from the surface. However, some alkali metals such as lithium, sodium, potassium, caesium and rubidium were sensitive even to visible light.

All these photosensitive substances emit electrons when they are illuminated by light. After the discovery of electrons, these electrons were termed as photoelectrons. The phenomenon is called photoelectric effect.